

THIS DRAWING IS UNPUBLISHED. RELEASED FOR PUBLICATION AUGUST, 2005.
 © COPYRIGHT 2005 BY TYCO ELECTRONICS CORPORATION. ALL RIGHTS RESERVED.

LOC	DIST	REVISIONS					
		P	LTR	DESCRIPTION	DATE	DWN	APVD
E	B	C		ECR-05-006587	03AUG05	JMS	FWK

- NOTES:
- 1. SINGLE PACK IN ACCORDANCE WITH AMP SPEC 107-3275
 - 2. 50 TRAY PACK IN ACCORDANCE WITH AMP SPEC 107-3275
 - 3. Au PLATING OVER Ni PLATING OVER Cu PLATING
 - 4. Ni PLATING OVER Cu PLATING
 - 5. TIN PLATING
 - 6. RECOMMENDED SELF-TAPPING SCREW 221108-4
 - 7. RECOMMENDED MOUNT NUT 1-1634816-0
 - 8. RECOMMENDED LOCKWASHER 1-1634817-0
 - 9. CHARACTERISTICS

FREQUENCY RANGE:	DC - 4GHz
NOMINAL IMPEDANCE:	50 OHMS
WORKING VOLTAGE:	500V RMS
INSULATION RESISTANCE:	5000 MOHMS
DIELECTRIC WITHSTAND VOLTAGE:	1500V RMS
CONTACT RESISTANCE:	
CENTRE CONTACT:	1.5 mOHMS
OUTER CONTACT:	0.2 mOHMS
 - 10. MECHANICAL CHARACTERISTICS

DURABILITY:	50 CYCLES
-------------	-----------
 - 11. FOR TECHNICAL DATA REFER TO YOUR LOCAL TYCO ELECTRONICS SALES OFFICE
 - 12. ALL DIMENSIONS ARE NOMINAL FOR REFERENCE ONLY UNLESS OTHERWISE STATED

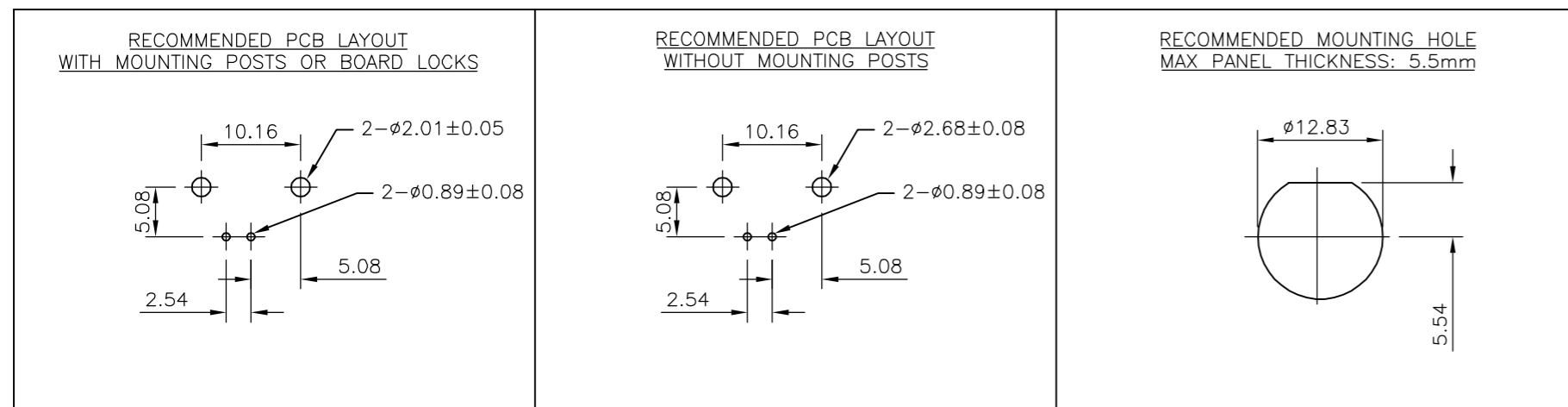
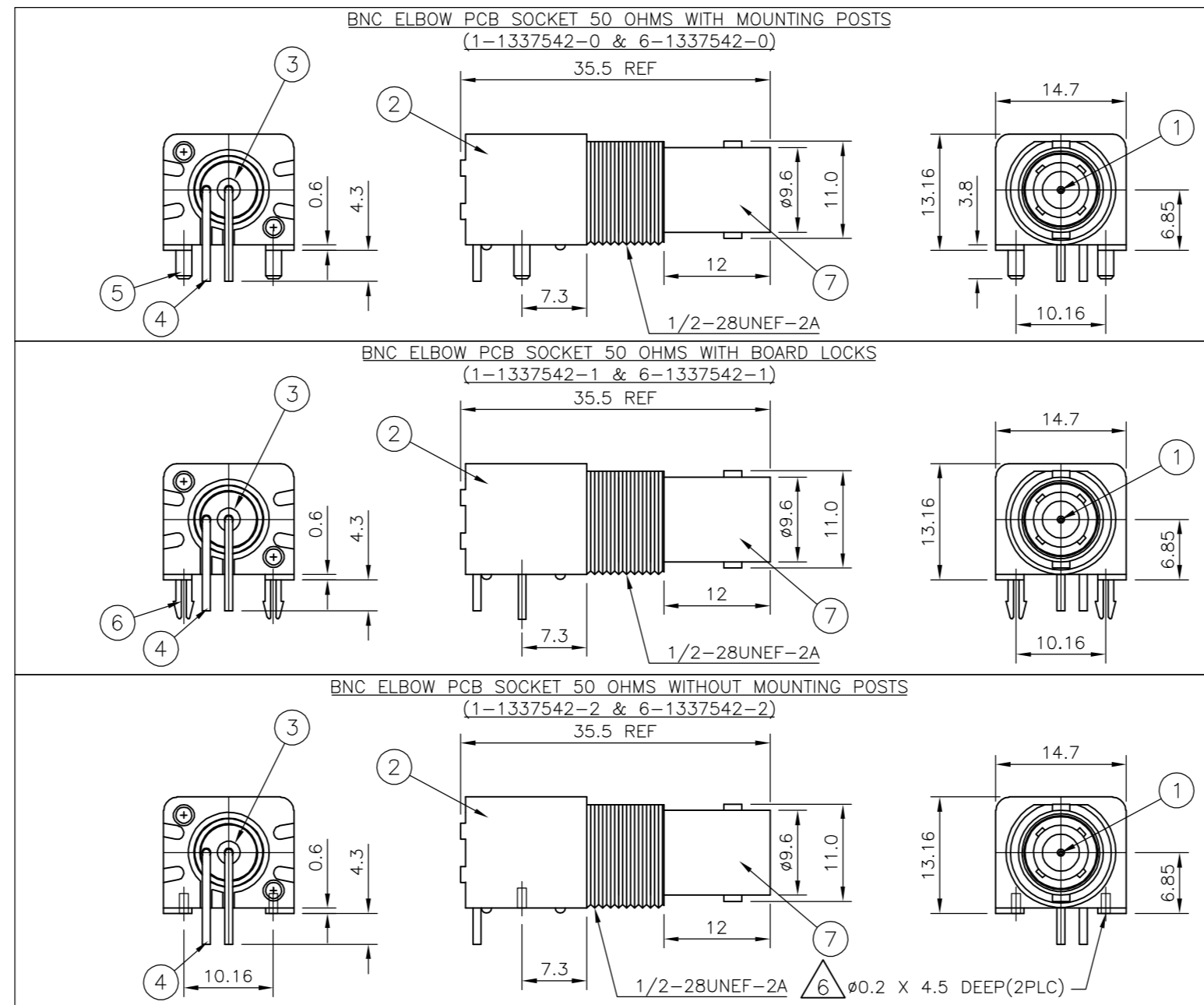

QTY	DESCRIPTION	MATERIAL	ITEM					
1	1	1	1	ZINC DIECAST	△	BODY	7	
-	-	2	-	BRASS	△	BOARD LOCK	6	
-	-	-	2	BRASS	△	MOUNTING POST	5	
1	1	1	1	BRASS	△	SOLDER TAIL	4	
1	1	1	1	PE-606		INSULATOR	3	
1	1	1	1	PBT WHITE		HOUSING	2	
1	1	1	1	BRASS	△	CONTACT	1	
6--2	1--2	6--1	1--1	6--0	1--0	MATERIAL	DESCRIPTION	ITEM

THIS DRAWING IS A CONTROLLED DOCUMENT.

DWN	J.SANDWELL	03AUG05
CHK	S.PARLOW	03AUG05
APVD	F.WHEELER-KING	03AUG05
PRODUCT SPEC	108-3435	
APPLICATION SPEC	108-3435	
WEIGHT	-	
CUSTOMER DRAWING		

tyco Electronics Tyco Electronics Corporation
Bideford, UK, EX39 4HE

NAME: BNC LOW PROFILE R/A INSULATED PCB SOCKET
50 OHM WHITE

SIZE: A2 CAGE CODE: 00779 DRAWING NO: C=1337542 RESTRICTED TO: -

SCALE: NTS SHEET: 1 OF 1 REV: C